

TM[®]-19 FORMER

OPERATING FEATURES

- ▶ Forming speeds at up to 80 strokes per minute
- ▶ Custom designed program with user friendly maintenance screens
- ▶ Custom designed feed screw mounting supports



*The **TM[®]-19** is a medium size forming machine operating products at speeds of up to 80 strokes per minute or process 4,500lbs (2042 kgs) per hour. With its full 19 inches (483mm) of usable width. This machine is highly favored in the forming industry due to its size, output capacity, and versatility.*

TM-19 FORMER SPECIFICATIONS

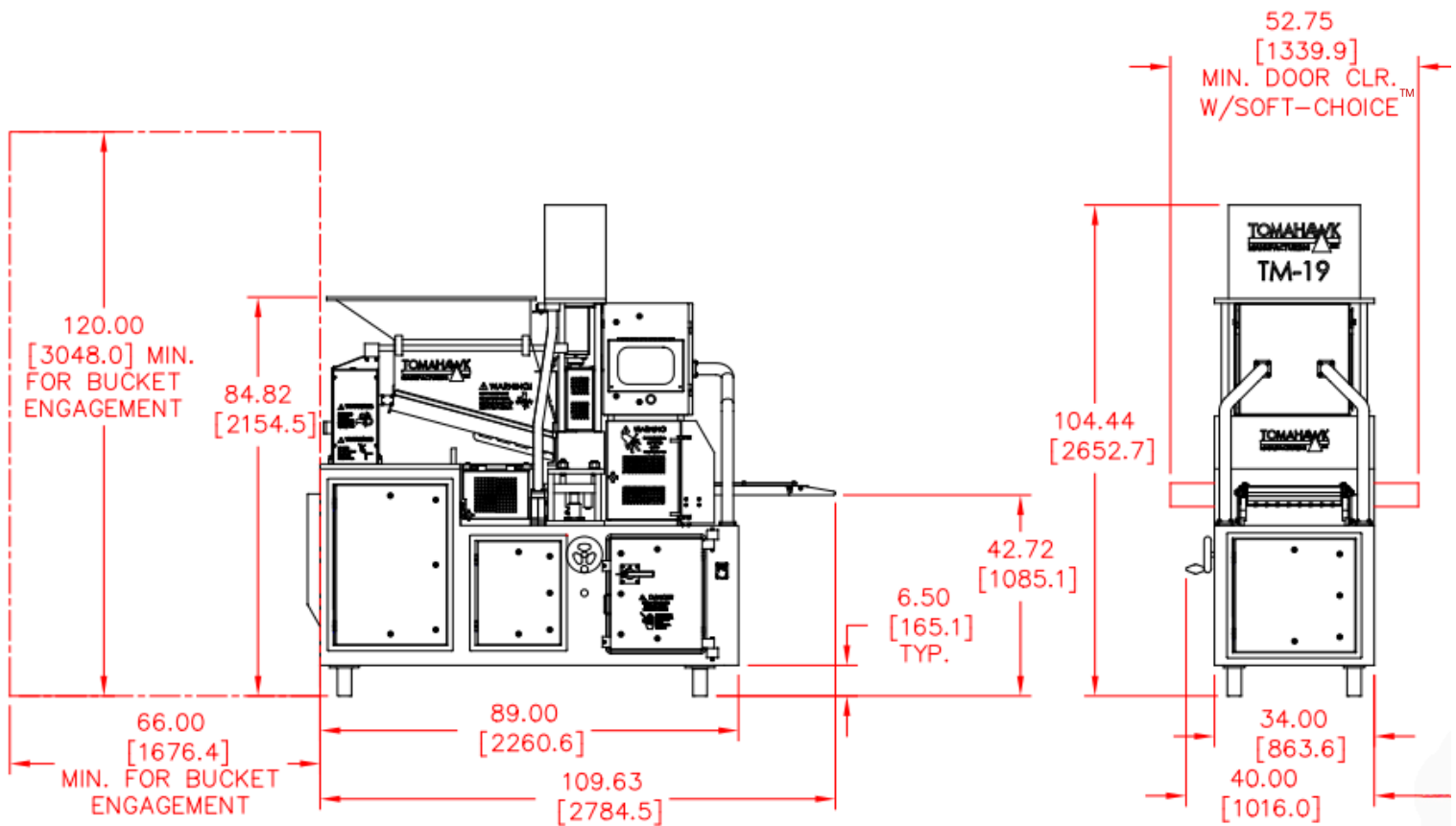

MECHANICAL FEATURES

- ▶ Allen-Bradley® Controls
- ▶ Etched Guards
- ▶ NEMA® Frame doors with Cam Locks
- ▶ Stainless Steel Hydraulic Tank
- ▶ Heavy-duty reinforced frame and deck

Tomahawk Manufacturing Inc.

Plymouth, WI
+1 (920) 458-8008
sales@tomahawkmfg.com

Tomahawk Manufacturing B.V.

Rijswijk, Netherlands
+31 70 222 7800
sales@tomahawkmfgeu.com

Allen-Bradley® a registered trademark of Rockwell Automation

NEMA® Electrical components a registered trademark of National Electrical Manufacturers Association