

TM[®]-6 FORMER

OPERATING FEATURES

- ▶ Forming speeds of up to 65 strokes per minute
- ▶ HMI with custom designed program and user-friendly maintenance features
- ▶ Quick and easy tooling changeovers



*The **TM[®]-6** is a smaller size forming machine capable of running paper products up to 65 strokes per minute or processing 2,000lbs (907kgs) per hour. With its full 6 inches (153mm) of usable width helping to increase your productivity for a higher product output.*

TM[®]-6 FORMER SPECIFICATIONS

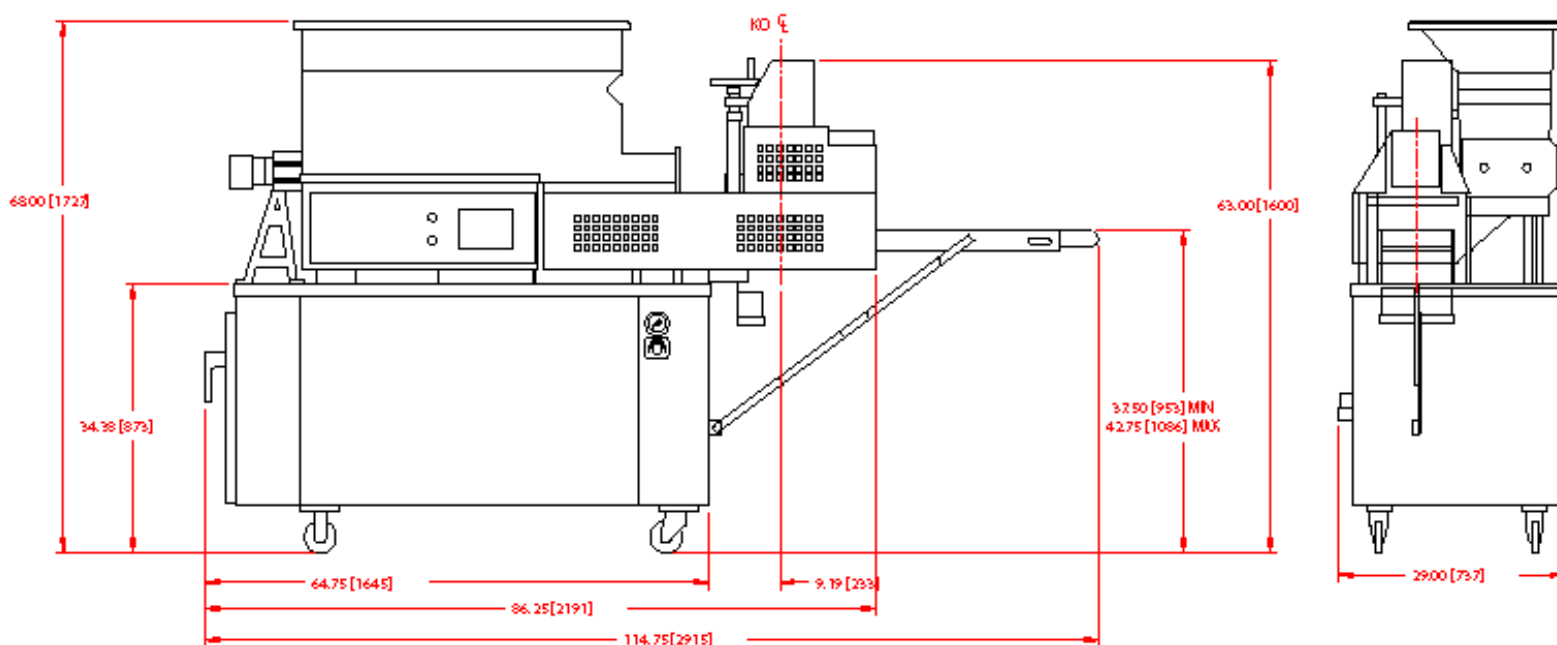

MECHANICAL FEATURES

- ▶ Allen-Bradley[®] Controls
- ▶ Etched Guards
- ▶ Stainless Steel Hydraulic Tank

Tomahawk Manufacturing Inc.

Plymouth, WI
+1 (920) 458-8008
sales@tomahawkmfg.com

Tomahawk Manufacturing B.V.

Rijswijk, Netherlands
+31 70 222 7800
sales@tomahawkmfgeu.com